

**Item Number**  
RAM-VB-174

# RAM No-Drill™ Seat Bases

National Products, Inc.

Vehicle base for the  
**VOLKSWAGEN BEETLE (1998-2007)**  
**VOLKSWAGEN JETTA (2000-2004)**

## SPECIFICATIONS

### Placement

Lower Front of Passenger Side Seat

### Drilling Required

No

### Seat Configuration

Bucket

### Pole or Pedestal

Sold Separately

### Construction/Finish

Steel/Black Powdercoat

### Weight

N/A

### Dimensions

A = 10.65", B = 6.74", C = 12"

## Features

Installs with no drilling required  
Low profile minimized intrusion into passenger leg space



Shown In Use

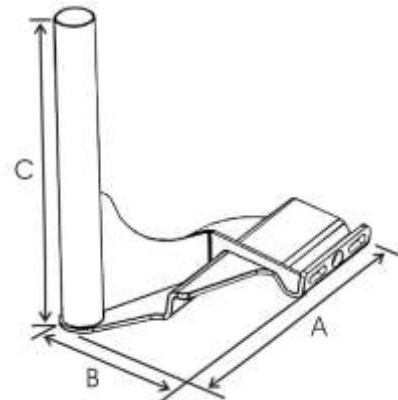

RAM-VB-174

---

National Products, Inc.  
Phone: 206-763-8361  
Fax: 206-763-9615  
Address: 1205 S Orr St  
Seattle, WA 98108  
Website: [www.ram-mount.com](http://www.ram-mount.com)  
Email: [staff@ram-mount.com](mailto:staff@ram-mount.com)



**Item Number**  
RAM-VB-174

# RAM No-Drill™ Seat Bases

National Products, Inc.

## Vehicle base for the **VOLKSWAGEN BEETLE (1998-2007)** **VOLKSWAGEN JETTA (2000-2004)**

### INSTALLATION INSTRUCTIONS

You will need the following tools:  
2 qty 13 MM box end wrench

Please read completely through the instructions prior to installation.

1. Using a 13 MM socket, remove the two nuts at the front of the seat rail. This is located near the floor board at the front center of the passenger side seat.
2. Once the two nuts are removed, set them aside. Remove the two factory bolts that pass through the floor bracket and seat rail. Store these should you later decide to remove the No Drill™ base. It may be necessary to use a soft mallet or brass hammer to tap these bolts out. Use care when removing these bolts so as not to damage the seat. They can be removed.
3. Replace the two bolts removed with the two longer bolts supplied with the No Drill™ kit. Place the lock washer over the bolt then pass each through the seat rail and bracket exactly like the factory bolts were. The bolts supplied are M8 x 60. Make sure the bolts pass through the aluminum seat rail and the floor bracket. Push the bolts as far forward and through the floor bracket as possible.
4. Place the No Drill™ base slots over the top of the end of the bolts, place the supplied flat washer over the threads, start the nuts over the bolts by hand. Using the 13 MM wrench, fully tighten the nuts to secure the No Drill™ base in place.

Hint: To ease access to the heads of the provided hex bolts once installed, you may want to separate the plastic skirt trim that goes around the base of the seat. The seam is held together by a plastic clip. Gently separate the two halves to expose a phillips head screw. Remove this screw and part the two skirts to allow for easier access to the underside of the seat. Using the boxed or closed end of the 13MM wrench, place that over the head of the hex bolt to keep it from spinning while you use the other 13 MM box end wrench to tighten the nut at the front.

**Note:** Once installed, seat travel in some VW models will be lessened.



National Products, Inc.  
Phone: 206-763-8361  
Fax: 206-763-9615  
Address: 1205 S Orr St  
Seattle, WA 98108  
Website: [www.ram-mount.com](http://www.ram-mount.com)  
Email: [staff@ram-mount.com](mailto:staff@ram-mount.com)

