

**Item Number**  
RAM-VB-154

# RAM No-Drill™ Seat Bases

National Products, Inc.

**Vehicle base for the**  
**NISSAN PATHFINDER (2005-NEWER)**  
**NISSAN XTERRA 4X4 ONLY (2005-2006)**  
**NISSAN FRONTIER 4X4 ONLY (2005-NEWER)**

## SPECIFICATIONS

### Placement

Passenger side, front, where seat rail frame attaches to floor board.

### Drilling Required

No - uses existing seat bolts

### Seat Configuration

Bucket

### Construction/Finish

Steel/Black Powdercoat

### Pole or Pedestal

Sold Separately

### Weight

2.8 lbs.

### Dimensions

A = 20.25", B = 7.25", C = 3.5"  
Hole Center = 17.25"

## Features

Installs in minutes with no drilling required  
Low profile keeps mount away from passenger leg space

## Misc.

Rock solid construction

Lifetime warranty

National Products, Inc.  
Phone: 206-763-8361  
Fax: 206-763-9615  
Address: 1205 S Orr St  
Seattle, WA 98108  
Website: [www.ram-mount.com](http://www.ram-mount.com)  
Email: [staff@ram-mount.com](mailto:staff@ram-mount.com)



Shown In Use

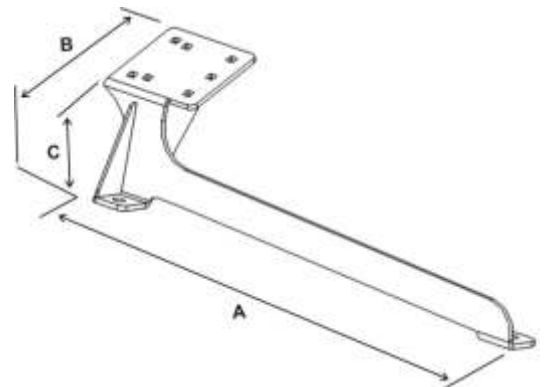

RAM-VB-154



**Item Number**  
RAM-VB-154

**RAM No-Drill™ Seat Bases**  
National Products, Inc.

**Vehicle base for the**  
**NISSAN PATHFINDER (2005-NEWER)**  
**NISSAN XTERRA 4X4 ONLY (2005-2006)**  
**NISSAN FRONTIER 4X4 ONLY (2005-NEWER)**

## **INSTALLATION INSTRUCTIONS**

1. Move the passenger seat back to its rearmost position and remove the front seat rail bolts. Store these bolts.
2. Without moving the seat, place the No-Drill™ base over the front of the seat frame
3. Align the holes in the metal base with those in the seat frame and floor board.
4. Re-install the new longer seat bolts and washers included with your kit and fully tighten.

National Products, Inc.  
Phone: 206-763-8361  
Fax: 206-763-9615  
Address: 1205 S Orr St  
Seattle, WA 98108  
Website: [www.ram-mount.com](http://www.ram-mount.com)  
Email: [staff@ram-mount.com](mailto:staff@ram-mount.com)

