

Item Number
RAM-VB-134

RAM No-Drill™ Seat Bases

National Products, Inc.

Vehicle base for the
NISSAN TITAN (2004-NEWER)
NISSAN ARMADA (2004-NEWER)
INFINITI QX56 (2004-NEWER)

SPECIFICATIONS

Placement

Passenger side on the floor, under front seat

Drilling Required

No - uses existing seat bolts

Seat Configuration

Bucket

Construction/Finish

Steel/Black Powdercoat

Dimensions

A = 18.75", B = 8.625", C = 2"
Hole Centers = 17.5"

Pole or Pedestal

Sold Separately

Weight

6.3 lbs.

Features

Installs in minutes with no drilling required
Low profile keeps mount away from passenger leg space

Misc.

Rock solid construction

Lifetime warranty

National Products, Inc.
Phone: 206-763-8361
Fax: 206-763-9615
Address: 1205 S Orr St
Seattle, WA 98108
Website: www.ram-mount.com
Email: staff@ram-mount.com



Shown In Use

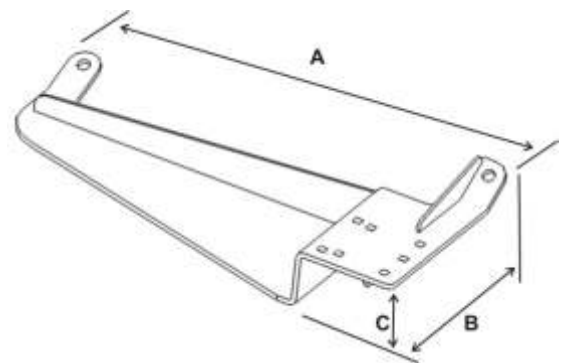

RAM-VB-134



Item Number
RAM-VB-134

RAM No-Drill™ Seat Bases

National Products, Inc.

Vehicle base for the
NISSAN TITAN (2004-NEWER)
NISSAN ARMADA (2004-NEWER)
INFINITI QX56 (2004-NEWER)

INSTALLATION INSTRUCTIONS

Note that the seat leg bolt on the passenger side closest to the door may be beneath a piece of plastic trim. Remove only the round center cover and store for later use.

1. Move the passenger seat back to its rearmost position.
2. Remove the round plastic plug cover using a small screw driver. Gently pry this up to expose the seat leg bolt. Store this cover for later use.
3. Remove both of the front seat rail bolts on the passenger side.
4. Once the bolts are removed, store the bolt that was removed from under the plastic cover for later use.
5. Place the stand off provided over the seat frame leg hole closest to the passenger door.
6. Align the holes in the base with those of the seat frame legs. The hole closest to the passenger side door should rest over the stand off providing clearance for the plastic trim piece remaining.
7. Pass the factory bolt nearest the center of the vehicle through the no drill base and begin the thread by hand.
8. Pass the longer seat leg bolt provided in the kit through the washer included in the kit, through the no drill base, through the stand off, and begin thread by hand into the floor board.
9. Once both seat leg bolts have been started, fully tighten using a socket wrench.
10. After a week of use, check seat leg bolt and re-tighten if necessary.

National Products, Inc.
Phone: 206-763-8361
Fax: 206-763-9615
Address: 1205 S Orr St
Seattle, WA 98108
Website: www.ram-mount.com
Email: staff@ram-mount.com

