

## Item Number

RAM-VB-129C & RAM-VB-129C-SW1

# RAM No-Drill™ Seat Bases

National Products, Inc.

## COMPATIBLE VEHICLES:

**DODGE CHARGER POLICE PACKAGE (2011)**

**DODGE CHARGER NON-POLICE (2011)**

## SPECIFICATIONS

### Placement

Passenger side on horizontal section of seat rail.

### Drilling Required

No - uses existing seat bolts

### Seat Configuration

Bucket

### Construction/Finish

Steel/Black Powdercoat

### Dimensions

A = 19.375" B = 7.125"

Hole Center = 16.5"

### Pole or Pedestal

Purchased Separatel

**Weight = 4.9 lbs.**

## Features

Installs with no drilling required  
Minimal intrusion into passenger leg space

## Important Note

In 2011 model year vehicles, the seat leg bolts may be tied to the air bag system. Tampering with these may result in disabling the air bag system and causing a severe safety hazard. The installation of this product into these vehicles should only be done by a Dodge factory authorized technician or Up-fitter familiar with Police, Fire, and Rescue vehicles and their fleet use.

National Products, Inc.  
Phone: 206-763-8361  
Fax: 206-763-9615  
Address: 1205 S Orr St  
Seattle, WA 98108  
Website: [www.ram-mount.com](http://www.ram-mount.com)  
Email: [staff@ram-mount.com](mailto:staff@ram-mount.com)



RAM-VB-129C-SW1

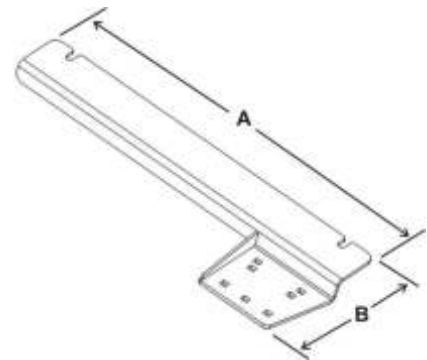

RAM-VB-129C



## Item Number \_\_\_\_\_

RAM-VB-129C & RAM-VB-129C-SW1

# RAM No-Drill™ Seat Bases

National Products, Inc.

## COMPATIBLE VEHICLES:

**DODGE CHARGER POLICE PACKAGE** (2011)

**DODGE CHARGER NON-POLICE** (2011)

## INSTALLATION INSTRUCTIONS

You will need an E12 socket for installation of the RAM-VB-129C base. If you are using a RAM Tele-Pole™ system, attach the lower female tube prior to installing the No-Drill™ base in the vehicle. It is suggested to install the mounting hardware so the rubber nut caps are on the top side.

1. Loosen the seat leg bolts on the passenger side that hold the seat to the floor pan. These are located at the front center of the seat tracks. It is not necessary to remove these. Only loosen them enough to clear the no drill base.
2. Once the bolts are loose, gently lift the front of the seat to create enough space for the base to fit between the seat frame legs and floor board.
3. Align the slots with the seat leg bolts and slide the base completely under the legs until the back of the slots contacts the seat leg bolts.
4. Fully tighten the seat leg bolts to secure the No-Drill™ base in place.



National Products, Inc.  
Phone: 206-763-8361  
Fax: 206-763-9615  
Address: 8410 Dallas Ave S  
Seattle, WA 98108  
Website: [www.ram-mount.com](http://www.ram-mount.com)  
Email: [staff@ram-mount.com](mailto:staff@ram-mount.com)

