

Item Number
RAM-VB-119

RAM No-Drill™ Seat Bases

National Products, Inc.

Vehicle base for the FORD ECONOLINE VAN (1995-NEWER)

SPECIFICATIONS

Placement

Attaches to the passenger side inner front and back seat studs

Drilling Required

No - uses existing seat bolts

Seat Configuration

Bucket

Construction/Finish

Steel/Black Powdercoat

Dimensions

A = 16.75", B = 8.25", C = 18.75"

Hole Center = 13.5"

Tools required for base installation

18mm socket or T-55 torx for base installation.
Tools for complete system assembly: pliers, phillips screw driver, #10, 1/2", 9/16" box end wrench's.

Pole or Pedestal
Included on base

Weight
10.5 lbs.

Complete system
shown in use



Features

Installs in minutes with no drilling required. Supplied stabilizer can be used to brace the base against passenger side seat for added rigidity.

Misc.

Rugged Steel Construction
Lifetime warranty

National Products, Inc.
Phone: 206-763-8361
Fax: 206-763-9615
Address: 1205 S Orr St
Seattle, WA 98108
Website: www.ram-mount.com
Email: staff@ram-mount.com

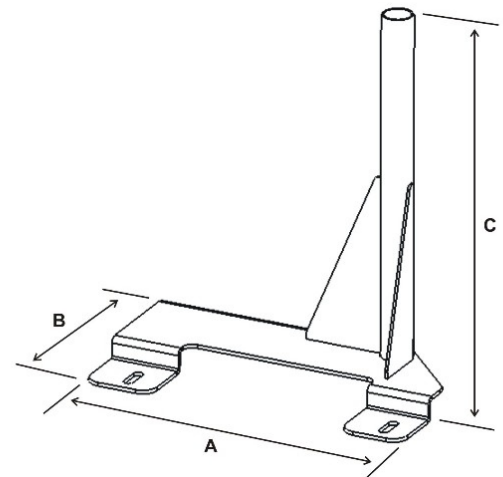

RAM-VB-119
Supplied stabilizer not shown



Item Number
RAM-VB-119

RAM No-Drill™ Seat Bases
National Products, Inc.

Vehicle base for the FORD ECONOLINE VAN (1995-NEWER)

INSTALLATION INSTRUCTIONS

The RAM-VB-119 No-Drill™ base installs on the inside of the passenger seat with the pedestal forward. The inner front and inner rear seat frame bolts secure the base in place. Use the supplied stabilizer brace for added rigidity as needed.

Tools needed for installation are 7/16" box end wrench, T-55 torx bit, and 18mm deep socket, socket wrench.

1. Using the 18mm deep socket and T-55 torx bit, loosen and remove the hardware holding the seat frame to the floor board.
2. Raise the inside of the seat frame off of the floor enough to allow the No Drill base to be placed over the hole and stud now exposed on the vehicle floor. Placement is between the seat frame and floor board, inside front and inside rear of passenger seat hardware.
3. Gently lower seat back into place so that the No Drill base is between the seat frame and floor board.
4. Re-install the previously removed hardware and fully tighten to 35 ft lbs.

Note: An "L" shaped stabilizer is included with this kit. One of the gussets has a mounting hole and slot to accommodate this bracket. If using the bracket, attach this prior to installing the base into the vehicle. This is not always necessary but installing ahead of time allows for more room to work with your tools. Leave the bracket just loose and do the final adjustment once the base is installed and seat frame fully tightened to floor board. Using the supplied 1/4-20 hardware, attach the bracket to the base with the 7/16" box end wrench. The part number for this kit is RMR-HAR-VB-119. Kit includes hardware and "L" bracket only.



National Products, Inc.
Phone: 206-763-8361
Fax: 206-763-9615
Address: 1205 S Orr St
Seattle, WA 98108
Website: www.ram-mount.com
Email: staff@ram-mount.com

