

Item Number
RAM-VB-110

RAM No-Drill Seat Bases

National Products, Inc.

Vehicle base for the
Ford Expedition (1997-2010)
F Series F-150 (1997-2003)
F-250 Light Duty (1997-Newer)

SPECIFICATIONS

Placement

Passenger side floor board, under seat

Tools required for base installation

18mm socket or T-55 torx for base installation.
Tools for complete system assembly: pliers,
phillips screw driver, #10, 1/2", 9/16" box end
wrench's.

Seat Configuration
Bucket/Bench

Pole or Pedestal
Ordered Separately

Construction/Finish
Steel/Black Powdercoat

Weight
10.7 lbs.

Dimensions

A = 15.25", B = 8", C = 2.5", D = 6.25,
E = 19.75" Hole Center = 12.75"

Features

Installs in minutes with no drilling required
Step feature allows optimized placement of mount with a minimal
amount of intrusion of passenger leg space

Misc.

One Offset Universal Mount step is included with this vehicle base.
Additional steps can be ordered for stacking. Jack and Jack cover
located under seat in some models will have to be relocated to allow
this base to fit. Consider attaching riser prior to base installation.



Shown In Use

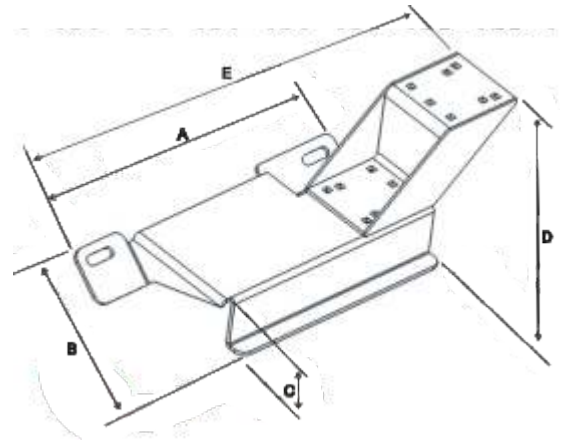

RAM-VB-110, SHOWN WITH
RAM-VB-SB4 RISER (INCLUDED)

National Products, Inc.
Phone: 206-763-8361
Fax: 206-763-9615
Address: 1205 S Orr St
Seattle, WA 98108
Website: www.ram-mount.com
Email: staff@ram-mount.com



Item Number
RAM-VB-110

RAM No-Drill Seat Bases

National Products, Inc.

Vehicle base for the
Ford Expedition (1997-2010)
F Series F-150 (1997-2003)
F-250 Light Duty (1997-Newer)

INSTALLATION INSTRUCTIONS

Kit includes longer seat leg bolts and stand offs for the 2008 and Newer Ford Expedition. These are not used on any other vehicles listed. Use factory hardware and instructions below for all other vehicles.

1. Attach the RAM-VB-SB4 riser to base with the provided carriage bolts, washers, and nuts tightening with the ½" box end wrench.
2. Move the passenger seat to the rearmost setting.
3. Remove the front seat rail bolts that fasten the passenger seat brackets to the vehicle floor using the 18mm or T55 torx bit.
4. Without moving the seat, place the base over the front of the seat bracket.
5. Re-install the seat bolts through the base, then the seat frame legs, and into the vehicle floor board. Start the thread by hands. Fully tighten / torque the seat leg bolts to 39 ft lbs.

Note that for the 2008 and newer Expedition, the stand off kit included will be necessary for installation. The longer seat leg bolts and short sections of steel tubing allow for angle correction in these models. Place the stand offs in between the No-Drill™ base and the seat legs and pass the longer bolts with washers through and start the thread by hand. Fully tighten as stated in step 5 above.

National Products, Inc.
Phone: 206-763-8361
Fax: 206-763-9615
Address: 1205 S Orr St
Seattle, WA 98108
Website: www.ram-mount.com
Email: staff@ram-mount.com

