

Item Number
RAM-VB-108

RAM No-Drill™ Seat Bases

National Products, Inc.

Vehicle base for the

FORD F-250 to F-750 SUPER DUTY, AUTOMATIC ONLY (1999-2010)
FORD EXCURSION (2000-2005)
FORD EXCURSION LIMITED (2000-2005)

Specifications

Placement

Passenger side floor board, under seat

Seat Configuration

Bucket/Bench

Construction/Finish

Steel/Black Powdercoat

Dimensions

A = 18.75", B = 5.63", C = 6.437", D = 13.25"
Hole Center = 11.5"

Pole or Pedestal

Purchased Separately

Weight

9.4 lbs.

Tools required for base installation

18mm socket or T-55 torx for base installation. Tools for complete system assembly: pliers, phillips screw driver, #10, 1/2", 9/16" box end wrench's.

Features

Installs in minutes with no drilling required

Step feature allows optimized placement of mount with a minimal amount of intrusion of passenger space

Important note

In the Ford Excursion Limited and Eddie Bauer editions, the heater duct prevents access to left seat stud. The mount can be used by removing the carpet and plugging the heater duct. If this is unacceptable, the RAM-VBD-101 can be used as an alternative.

Complete system shown in use

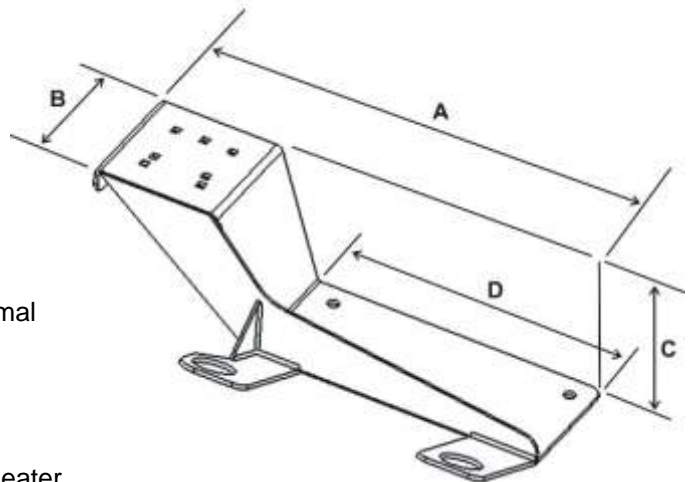

RAM-VB-108

National Products, Inc.
Phone: 206-763-8361
Fax: 206-763-9615
Address: 1205 S Orr St
Seattle, WA 98108
Website: www.ram-mount.com
Email: staff@ram-mount.com



Item Number
RAM-VB-108

RAM No-Drill™ Seat Bases
National Products, Inc.

Vehicle base for the

FORD F-250 to F-750 SUPER DUTY, AUTOMATIC ONLY (1999-2010)
FORD EXCURSION (2000-2005)
FORD EXCURSION LIMITED (2000-2005)

Installation instructions

Bucket Seat Instructions:

Tools required for installation are a T-55 torx bit, 18mm socket and socket wrench.

1. Remove the front seat bolts from the passenger side of the seat. This may require the use of a T-55 Torx Bit or an 18mm socket. While lifting the front of the seat, slide the legs of the RAM-VB-108 under the passenger seat frame legs. Center the base so that the seat frame legs are over the large round holes in the no drill base. The depressions in the seat frame legs will locate themselves into the round openings of the No Drill base.
2. After the seat is lowered over the No Drill base, start the seat leg bolts by hand into the threaded holes in the floor board.
3. Using the T-55 Torx or 18mm socket, fully tighten the seat leg bolts to 39 ft lbs securing the No Drill base into place.

Bench Seat Instructions:

1. Remove the front seat bolts from the passenger side of the seat. While lifting the front of the seat, slide the legs of the RAM-VB-108 under the passenger seat mounting bracket. Center the legs under the passenger seat mounting bracket and lower the seat back into place.
2. Most Ford floor pans (when used with a bench seat) have a hole in the floor with a welded nut on the underside of the vehicle. This hole is often covered with a plastic plug. If there is no hole previously placed in the floor pan from the factory, you must drill a hole.
3. Cut a small hole in the floor covering and remove the plastic plug.
4. Place the included bench seat washer in the hole of the inner leg of the RAM-VB-108. Align the hole in the spacer with the hole in the floor.
5. Fasten down the inner leg of the RAM-VB-108 with the M12 X 38MM long bolt, and bench seat washer that was supplied in the hardware bag. If you had to drill a hole in the floor you will need to fasten down the base with a fender washer and lock nut on the under side of the vehicle.
6. Fasten the passenger seat and the outer leg of the RAM-VB-108 with the seat bolt you removed earlier.

National Products, Inc.
Phone: 206-763-8361
Fax: 206-763-9615
Address: 1205 S Orr St
Seattle, WA 98108
Website: www.ram-mount.com
Email: staff@ram-mount.com

