

**Item Number**  
RAM-VB-107

# RAM No-Drill™ Seat Bases

National Products, Inc.

**Vehicle base for the  
CHEVROLET CAPRICE (1990-1995)  
FORD CROWN VICTORIA/POLICE INTERCEPTOR (1991-2010)**

## SPECIFICATIONS

### Placement

Across transmission hump

### Pole or Pedestal

Ordered Separately

### Drilling Required

No - uses existing seat bolts

### Weight

7.3 lbs.

### Seat Configuration

Bucket/60-40 split

### Construction/Finish

Steel/Black Powdercoat

### Dimensions

A = 8.75", B = 5", C = 5.75", D = 9.25"

## Features

Installs in minutes with no drilling required  
Central mounting location moves pole away from passenger leg space

## Misc.

Drilling may be required on some vehicles with 60-40 split seats



Shown In Use

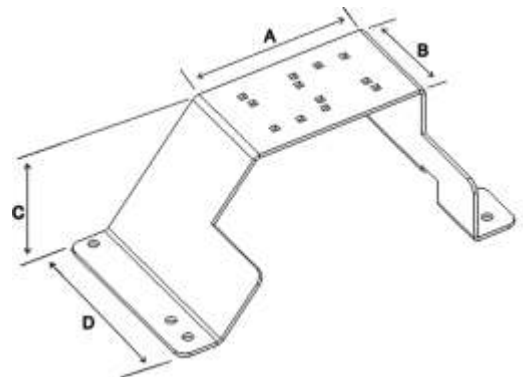

RAM-VB-107

National Products, Inc.  
Phone: 206-763-8361  
Fax: 206-763-9615  
Address: 1205 S Orr St  
Seattle, WA 98108  
Website: [www.ram-mount.com](http://www.ram-mount.com)  
Email: [staff@ram-mount.com](mailto:staff@ram-mount.com)



**Item Number**  
RAM-VB-107

**RAM No-Drill™ Seat Bases**  
National Products, Inc.

**Vehicle base for the  
CHEVROLET CAPRICE (1990-1995)  
FORD CROWN VICTORIA/POLICE INTERCEPTOR (1991-2010)**

## INSTALLATION INSTRUCTIONS

1. Place both front seats in their most rear position.
2. Remove the drivers side front right and the passenger side front left seat mounting bolts (inner seat bolts).
3. Slightly lift both the passenger and driver seats and slide the No-Drill base between the floor of the vehicle and the bottom of the seat.
4. Align the holes and reinstall all of the seat bolts that have been removed.

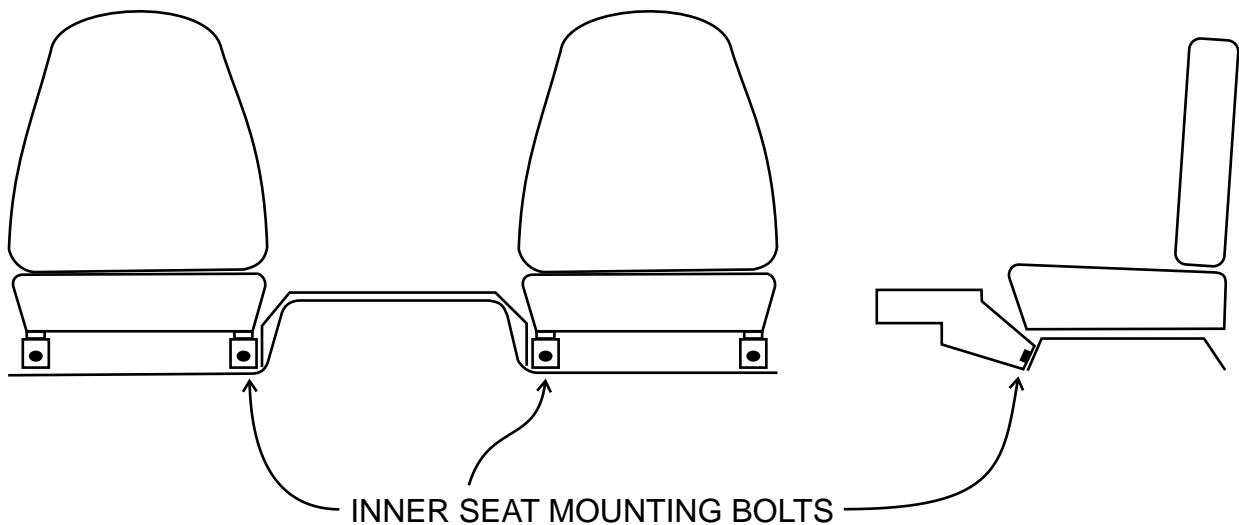

National Products, Inc.  
Phone: 206-763-8361  
Fax: 206-763-9615  
Address: 1205 S Orr St  
Seattle, WA 98108  
Website: [www.ram-mount.com](http://www.ram-mount.com)  
Email: [staff@ram-mount.com](mailto:staff@ram-mount.com)

